



Fibromax Compact MR Black

Recommendations



1. Introduction	4
2. Applications	4
3. Storage	5
4. Surface finishing	5
5. Processing	6
6. Edge finishing	6
7. Installation	7
8. Disclaimer	7

1. Introduction

Fibromax Compact MR Black is a **raw, black core coloured fibreboard** with a density of **> 1000 kg/m³**.

Fibromax Compact MR Black is a **very robust, high-quality** board, with excellent **physical** and **mechanical** properties (very low swelling, high internal bond, strong resistance to impact, etc...).

The board can be **machined easily** (e.g. sawing, drilling & milling) and can be **finished** with melamine, HPL, wood veneer, etc.

The board has **low formaldehyde** emission (E1 class).

Fibromax Compact MR Black is made from **100% recovered wood**: 100% pre-consumer wood from waste flows from the wood industry or thinned wood from sustainable forestry and verge management.

2. Applications

After finishing with a surface layer, the Fibromax Compact MR Black board can a.o. be used for the following applications:

- Dressing & fitting rooms
- Lockers
- Wardrobes & cloak rooms
- Tables & desks
- Worktops
- Benches & beds
- Wall panelling & boarding
- Room dividers & partitions
- ...

The product is not suitable for:

- Outdoor use
- Applications where it is subject to prolonged or frequent exposure to water, e.g.:
 - Showers
 - Swimming pools

3. Storage

The product should be stored:

- In its original packaging.
- On a flat and horizontal surface.
- In a closed, sufficiently ventilated and dry place, where a stable humidity and temperature can be guaranteed.
- Protected against rain, frost, snow & direct sunlight.

4. Surface finishing

Similar to MDF, the surfaces of Fibromax Compact MR Black boards can be finished with HPL (High Pressure Laminate), wood veneer, etc ...

I. Acclimatization

Acclimatize the raw boards, the planned surface finish and the glue for at least 72 hours in the same room, with a temperature of +/- 20°C and a relative air humidity of max. 50%.

II. Gluing

The choice of glue depends on: the properties of the materials to be glued, the absorption power of the panel and the surface finish, the glue application method (by hand, roller or spray gun), press temperature, pressure and time under pressure, ...

The instructions of the glue supplier should always be respected (e.g. storage conditions of the glue, application type & -instructions, glue spread,).

III. Pressing (hot/cold press)

In contrast to gluing a surface finish on standard MDF boards, the parameters of the press (press time, press t°, ...) may need to be

adjusted. To allow good absorption of the glue, a longer press time might be indicated. Just after pressing, it is possible that the adhesion between the board and the surface finish is not optimal yet. This is a normal phenomenon, which will disappear after curing of the glue (see IV. Bonding) To ensure its stability, the boards should always be finished at both sides, with the same surface finishing.

In order to define the optimal press conditions, it is strongly advised to always perform a preliminary test on the industrial line with a limited number of panels.

IV. Bonding

To ensure good bonding, it is required to allow the glue for curing. Therefore, after pressing: let the boards rest for at least 24 hours in their original packaging, on a flat and horizontal surface in a warm environment (a more humid environment is not favorable) .

5. Processing

- Keep in mind that Fibromax Compact MR Black boards are harder and heavier than traditional MDF boards.
- For sawing and mechanical machining (drilling, milling), the standard tools to process other wood-based panels can be used.
 - However, to ensure the longevity, it is recommended to use diamond tipped tools (used e.g. to process thick compact HPL boards).
- In order to achieve a satisfactory result:
 - The use of the right tools is important (e.g. a saw blade with more teeth needs to be used).
 - Some production parameters (such as cutting speed, feed rate, etc...) might need adjustment.
- In order to select the right tools & define the correct parameters, it is strongly advised to perform a preliminary test.
- Consult your tool supplier for more information and advice.

6. Edge finishing

To improve the appearance of the edges or to protect them against moisture, abrasion or dirt, the edges can be finished. Examples of edge finishing:

- Chamfering
- Sanding with extra fine abrasive paper (P120>P280>P400)
- Sealing with a protective oil (e.g. Rubio Monocoat Oil Plus 2C)
- Edging tape
- Mitre joint installation



7. Installation

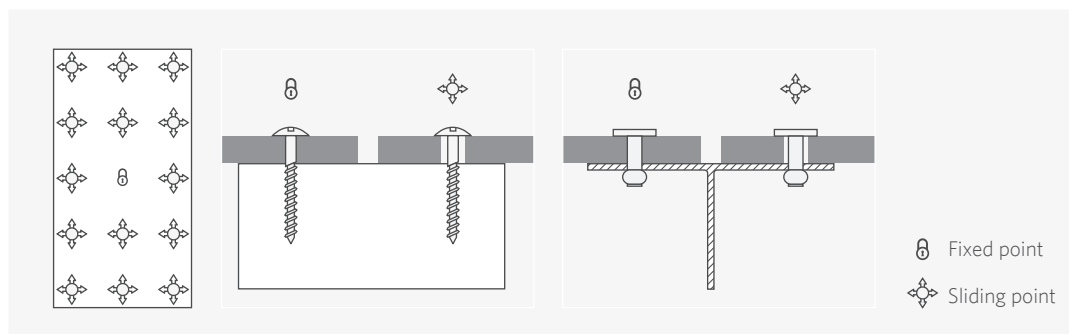

The following basic conditions should be respected before installation of the boards: the place of installation should be fully wind- and water proof. Boards should be acclimatized at the place of installation for at least 72 hours.

Especially in case of wall cladding and boarding, specific attention is required:

- direct fixation of the panels to a wall is not recommended, a substructure should be foreseen
- never install the boards onto a humid or wet wall or construction, or on walls or constructions that are subject to condensation
- a ventilated cavity might be required in some cases
- when using fixation materials, always consider possible dimensional changes of the product during the lifecycle of the installation.
- to allow dilation, a joint of min. 3mm/m between the boards should be foreseen. When using glues, they must be flexible to allow movement of the panels. Consult your glue supplier for more information and advice.
- if using screws, secure them with a washer or use screws with a head that completely covers the hole at maximum panel extension (see drawing)

8. Disclaimer

Colour

- The use of natural raw materials may result in:
 - colour differences between different production batches & panel thicknesses.
 - the appearance of non-coloured wood fibres, which is normal and a desired effect. On the panel's surface, the shape, density and size of these fibres might differ.
- For each project, it is recommended to use panels from the same production batch only, and to carefully select & assess the panels prior to installation.

Processing

- Before processing, the panels should be checked for any production defects and eventual deformation.
- Already processed panels, as well as all other direct and indirect costs, will not be subject to compensation by Unilin.

We strongly recommend you call upon experienced professional installers for a correct installation.

UNILIN, division panels

UNILIN, division panels – part of the UNILIN group – has been supplying innovative wood based solutions for building and interior design projects since 1960. Our chipboard, medium density fibreboard (MDF), High-Density fibreboard (HDF), High Pressure Laminate (HPL) and melaminefaced boards find their way to merchants in building materials and timber, industrial processors and DIY-chains worldwide.

We develop solutions tailored to your specific needs with creativity and innovation as the key drivers of our business. We continuously invest in product design and new technologies. Hence, we're recognized as a leading international player and a reliable partner in our niche sector.

Our 1,300 employees give their all, day after day, at our production units in Belgium, France, Germany and the Netherlands. Altogether we produce 2.1 million m³ of panels per year.